

# Technical specifications

## FR-CT60-IB (Inner bracket FR)

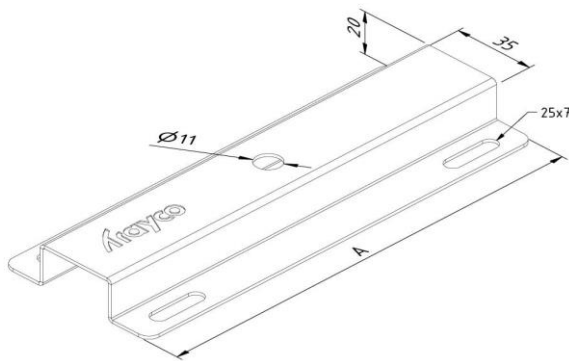

Finishing:		Pre-galvanized						
Product	Number	Height (mm)	Width (mm)	Length (mm)	Dim A (mm)	Fmax (kN)	Unit	Packaging (unit)
FR-CT60-IB-100-PG	13121	0	0	0	90		ST	10
FR-CT60-IB-150-PG	13123	0	0	0	140		ST	10
FR-CT60-IB-200-PG	13122	0	0	0	190		ST	10
FR-CT60-IB-300-PG	13206	0	0	0	290		ST	10
FR-CT60-IB-400-PG	13208	0	0	0	390		ST	10

### Mounting instructions:

-

### Load capacity:

Standard: -

Max. load: -

Load diagram: -

### Information:

Coupler: 2xN10+1xW10+4xBN6-10

Equipotential bonding: IEC61537

EC declaration: EC directive 2006/95/EC (Low voltage) as modified by directive 93/68/EEC (CE marking)

PG

Sendzimir galvanized (EN 10143) PG (pre-galvanized)

Products made of Sendzimir (pre-galvanized) or continuous hot-dip galvanized steel sheet and coils are mostly used wherever limited chemical contamination is likely, for example, in offices, industrial buildings, covered parking lots, etc.

Characteristic of this steel type is that – prior to mechanical deformation – it is given a zinc coating by means of a continuous dipping process. This zinc coating is easily deformed. A cathodic action occurs on cut surfaces (up to 1.5mm) that protects against oxidation.

First, the steel is chemically cleaned and roughened in order to achieve a good bond. After the dipping process, the surplus zinc is blown off and one obtains an extra passivating coat (an ultra-thin protective coat) to prevent oxidation of the zinc coating (white rust). The coating thickness is usually expressed in g/m<sup>2</sup>. The most deployed type of Sendzimir steel is Z 275 = 275g/m<sup>2</sup> (weighed on both sides), this corresponds to 18-20 µm (micron).

Sendzimir galvanized steel sourced from modern galvanizing lines has, in general, a uniform, shiny appearance. The previous, common flowery surface is scarcely seen these days. This effect is obtained under the influence of lead but has no effect on the quality of the coating. The use of lead was banned due to the ever more stringent environmental standards.

Field of application according to resistance against corrosion:

Corrosion class	Atmospheric corrosion	Indoor environment	Outdoor environment	Surface treatments
C1	< 0,1µm	Heated buildings with neutral atmospheres: offices, shops, schools, hotels.		Electro-galvanized (EG) EN ISO 2081
C2	0,1 - 0,7µm	Unheated buildings where condensation may occur: sports halls, warehouses, shops.	Rural areas. Atmosphere with low impurities.	Pre-galvanized (PG) EN 10327 – EN 10143
C3	0,7 - 2µm	Production facilities with high moisture levels and some air impurities due to industrial processes: production plants.	City and industrial atmosphere, some impurities, coastal areas with low salt loads.	Dipped-galvanized (DG) EN ISO 1461
C4	2 - 4µm	Production facilities with high moisture levels and high air impurities due to industrial processes: swimming pools, Chemical industry.	Industrial areas and coastal areas with low salt load.	Dipped-galvanized (DG) EN ISO 1461 Polyester coating (CO) EN ISO 12944
C5-I	4 - 8µm	Polyester coating (CO)	Industrial areas with high moisture level and aggressive atmosphere.	Duplex (DU) [Dipped galvanized + Polyester coating] Stainless steel AISI 316L
C5-M	4 - 8 µm	EN ISO 12944	Coastal or offshore areas with salt load.	Duplex (DU) [Dipped galvanized + Polyester coating] Stainless steel AISI 316L